

Uni-Click® Dry Verge



Product features & benefits

- Mortar free
- All weather fixing
- Secure mechanical fixing avoids wind uplift problems
- Quick and easy to fit – no special tools required
- Available in 4 colours to blend in with roof tiles
- Neat attractive appearance
- Weatherproof and maintenance free
- Unaffected by settlement or differential movement
- UV stable
- Prevents entry of birds and large insects

Area of application

Suitable for:

- Refurbishment or new build on roofs from 12.5° to 90°
- Most makes and profiles of concrete interlocking tiles between 260-350mm batten gauge

Material

Dry Verge unit - UPVC
Eaves Closure - polypropylene
Ridge Closure - polypropylene
Ridge End Cap - polypropylene
Batten End Clip - stainless steel

Colours

Brown, Slate grey, Terracotta, Black

Dimensions

403mm long x 148mm wide x 56mm deep



Designed to provide a mortar-free and secure method of fixing concrete interlocking verge tiles. Its neat interlocking design provides a consistent appearance that requires no maintenance.

The new Click-system



Installation

Extend the tiling battens 20mm beyond the gable wall or bargeboard and nail a Batten End Clip to the end of every batten. Fix the Eaves Closure to the end of the fascia board or brickwork. Slide the first Uni-Click® Dry Verge unit over the Eaves Closure and the bottom tile. Nail into the tiling batten through the Batten End Clip.

As each successive verge tile is laid, engage a Uni-Click® Dry Verge unit with the one below on the underside of the unit and then click it over the top of the unit below and then slide it up into position nailing through the Batten End Clip into the batten. Insert a Ridge Closure into the last unit, interlocking the combs of each Uni-Click® Dry Verge unit at the apex. Screw fix the Ridge End Cap to the ridge batten.

When installing onto an existing verge the old mortar between the tiles and the undercloak must be removed prior to the verge units being fitted. The tile battens must overhang the gable wall or bargeboard by 20mm and a Batten End Clip nailed to each batten.

If a Batten End Clip is not being used we recommend that the batten is extended 30mm over the barge board or brickwork and 40mm (minimum) x 3.25mm ring shank nails are used to fix the verge units. Prior to fixing the batten ends must be in good condition with no signs of decay.

Klober Ltd

Unit 6F · East Midlands Distribution Centre · Short Lane · Castle Donington · Derbyshire · DE74 2HA
Tel. +44 (0)1332 813 050 · Fax +44 (0)1332 814 033 · www.klober.co.uk · info@klober.co.uk

KLOBER

Uni-Click® Dry Verge



Product codes

Dry Verge Unit left hand

Black	KR9765-0450
Brown	KR9765-0247
Slate Grey	KR9765-0429
Terracotta	KR9765-0152

Dry Verge Unit right hand

Black	KR9770-0450
Brown	KR9770-0247
Slate Grey	KR9770-0429
Terracotta	KR9770-0152

Eaves Ridge Closure

Black	KR973376
Brown	KR973336
Slate Grey	KR973330
Terracotta	KR973334

Half Round Ridge End Caps

Black	KR977276
Brown	KR977236
Slate Grey	KR977230
Terracotta	KR977234

Universal Angle Ridge End Caps

Black	KR977376
Brown	KR977336
Slate Grey	KR977330
Terracotta	KR977334

Packaging

Dry Verge Units

10 units per pack - 5 packs per carton

Eaves Ridge Pack

2 Ridge Closures, 2 Eaves Closures and nails - 20 packs per carton

Ridge End Pack

2 Ridge End Caps and 4 screws - 10 packs per carton

Batten End Clips

50 clips per pack - 10 packs

Weight (per carton)

14.3kg

Regulations

Complies fully with all relevant British Standards

Related products

The Klober Uni-Click® Dry Verge system may be used in conjunction with a wet or dry ridge system of your choice.

Typical verge detail

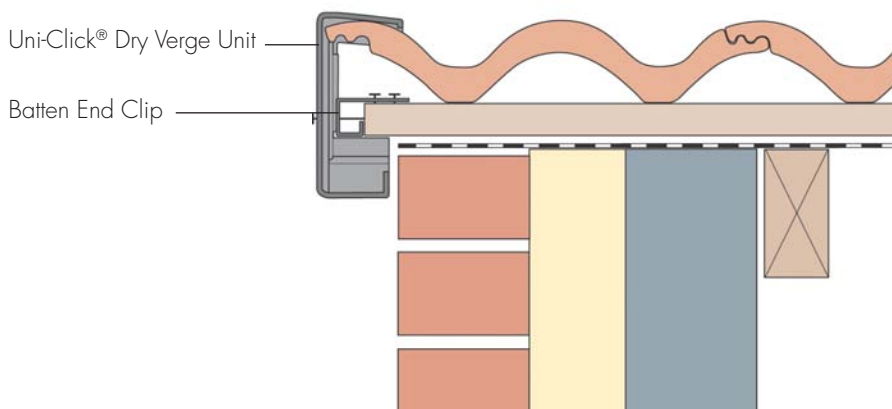

Dimensions

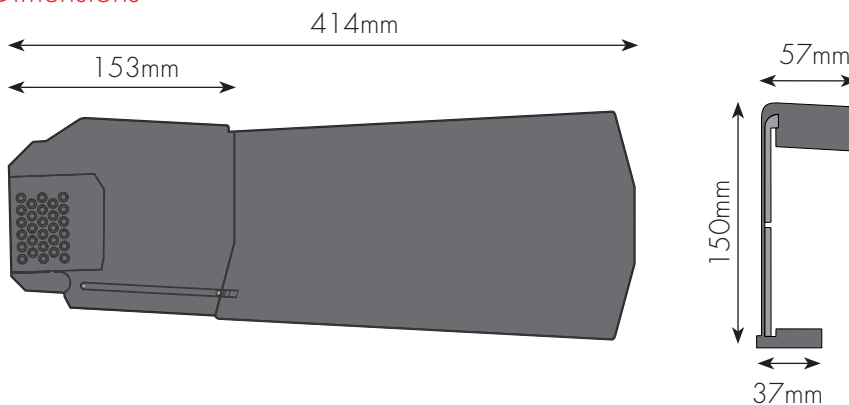

TS-05#48-UK-0415. We assume no liability for typing errors.

Klober Ltd

Unit 6F · East Midlands Distribution Centre · Short Lane · Castle Donington · Derbyshire · DE74 2HA
Tel. +44 (0)1332 813 050 · Fax +44 (0)1332 814 033 · www.klober.co.uk · info@klober.co.uk

KLOBER